

## Crio Smart 2 Door Digital Freezer, 1430lt (-22/-15) - Remote

ITEM # \_\_\_\_\_

MODEL # \_\_\_\_\_

NAME # \_\_\_\_\_

SIS # \_\_\_\_\_

AIA # \_\_\_\_\_



729122 (ARX142FFR)

2-door freezer 1430L, -22/-15°  
C, digital, AISI 304, remote

### Short Form Specification

**Item No.** \_\_\_\_\_

Two full doors freezer with internal and external structure in 304 AISI stainless steel; external back panel in galvanized steel and bottom panel in anti-corrosive material. Digital control with cabinet temperature display and setting and manual activation of defrost cycle. Fully compliant HACCP digital controls include visible alarms. Optimized back to front forced air flow provides even temperature distribution and fast cooling in any conditions. Fitted with 75 mm-thick cyclopentane insulating foam. Door features lock and door microswitch to switch off the fan when the door is opened. Hidden evaporator to guarantee higher storage capacity and less corrosion problems. Remote refrigeration unit; ventilated operation; automatic defrost and evaporation of defrost water. Dual operating temperature: -22/-15°C. For ambient temperatures up to 43 °C. CFC and HCFC free. R404a gas in refrigeration circuit.

Supplied with n. 6x2/1GN Rilsan coated grids and n. 6 sets of 2 stainless steel grid runners.

### Main Features

- Digital control with cabinet temperature display and setting and manual activation of defrost cycle. Fully compliant HACCP digital controls include visible alarms.
- Large storage area suitable to contain 2/1 GN grids or shelves on anti-tilt runners.
- Optimized back to front forced air flow provide even temperature distribution and fast cooling in any conditions.
- Automatic defrost.
- Internal structure with numerous charging positions available to host grids, ensuring higher net capacity and a greater storage space.
- Cabinet fitted with up to 75 mm thickness of cyclopentane insulation for best insulating performance with 100% environmental protection (thermal conductivity: 0,020 W/ m\*K).
- Removable triple-chamber balloon magnetic gasket to improve insulation and reduce energy consumption and ease of cleaning.
- 60 mm-thick insulation covering the evaporator can be easily removed with a single operation.
- Rilsan coated grids for improved protection.
- Hidden evaporator thus guaranteeing higher storage capacity and less corrosion problems.
- Two full doors.
- Freezer model has operating temperatures that can be adjusted from -22 to -15 °C.
- Connectivity ready for real time access to connected appliances from remote and data monitoring (requires optional accessory).

### Construction

- Constructed from the highest quality AISI 304 Stainless steel.
- Interior base with rounded corners, pressed from a single sheet.
- Stainless steel runners and supports easily disassembled.
- Anti-corrosion bottom avoids any damage that may be caused to the cabinet by aggressive detergents employed to clean the floors.
- Easy access to the main components for maintenance.
- Lockable door.
- Door switch stops the fan when door is opened to avoid cold air exiting the cell, thus saving energy.
- CFC and HCFC-free insulation.
- Mounted on adjustable Stainless steel feet, with castors as an option.
- Doors are self-closing and can be fully opened up to 180°.
- The rounded internal corners, the easily removable runners and grids allow for ease of cleaning and high hygiene standards.
- Remote refrigeration unit.
- Refrigerant type: R404a.

### Included Accessories

- 6 of 2/1GN gray rilsan grid PNC 881020 with 2 runners

APPROVAL: \_\_\_\_\_

### Optional Accessories

- |  |            |                          |
|--|------------|--------------------------|
| • Remote unit -22-15°C for 1430L refrigerated cabinets (R404a)                                     | PNC 880233 | <input type="checkbox"/> |
| • 2 stainless steel runners for refrigerated cabinets - (Marine)                                   | PNC 880242 | <input type="checkbox"/> |
| • 1/1GN set of 8 PVC containers for fish   | PNC 880243 | <input type="checkbox"/> |
| • Spacer for 670L and 1430L refrigerated cabinets  | PNC 880248 | <input type="checkbox"/> |
| • Kit integrated HACCP for digital refrigerators (IR33)  | PNC 880252 | <input type="checkbox"/> |
| • Kit to fit 20 pastry trays (400x600mm)   | PNC 880333 | <input type="checkbox"/> |
| • Plastic container with false bottom, 1/1GN   | PNC 880705 | <input type="checkbox"/> |
| • 2/1GN gray rilsan grid   | PNC 881004 | <input type="checkbox"/> |
| • AISI 304 stainless steel grid, 2/1GN   | PNC 881016 | <input type="checkbox"/> |
| • AISI 304 stainless steel grid with 2 runners, 2/1GN  | PNC 881018 | <input type="checkbox"/> |
| • 2/1GN gray rilsan grid with 2 runners  | PNC 881020 | <input type="checkbox"/> |
| • Set of 2 stainless steel runners for 670/1430L refrigerators and freezers                        | PNC 881021 | <input type="checkbox"/> |
| • Pedal opening for 1430L refrigerators  | PNC 881033 | <input type="checkbox"/> |
| • PVC container with lid and 2 runners, 2/1GN  | PNC 881039 | <input type="checkbox"/> |
| • 2/1GN perforated shelf   | PNC 881042 | <input type="checkbox"/> |
| • 1/1GN rilsan steel wire basket h150mm  | PNC 881043 | <input type="checkbox"/> |
| • 3 gray rilsan central grids for 1430L (not for glass door)                                       | PNC 881044 | <input type="checkbox"/> |
| • 2/1GN gray rilsan basket + 2 runners h150mm  | PNC 881047 | <input type="checkbox"/> |
| • 5 swivelling wheels (2 with brake), diam 125mm, for 1430 lt refrigerators, NOT for remote models | PNC 881294 | <input type="checkbox"/> |
| • KIT HACCP EKIS   | PNC 922166 | <input type="checkbox"/> |

**Front**

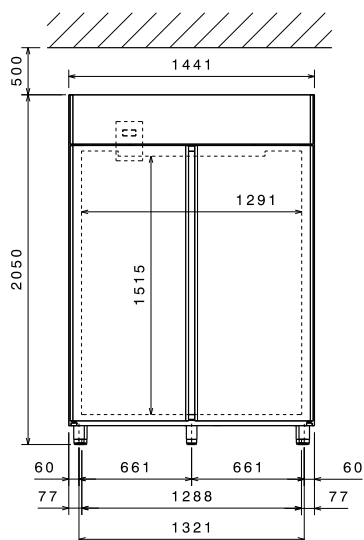

**Side**

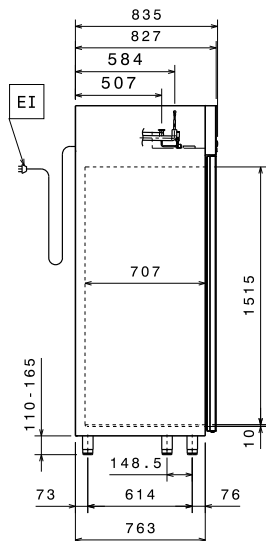

EI = Electrical inlet (power)  
RI = Refrigerant Inlet  
RO = Refrigerant Outlet

**Top**

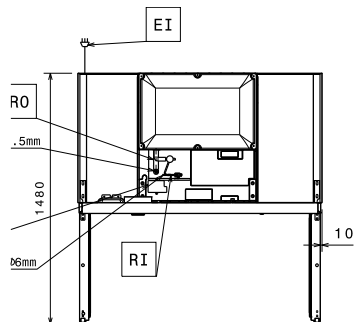

### Electric

Supply voltage:	729122 (ARX142FFR)	220-240 V/1 ph/50/60 Hz
Electrical power max.:		0.305 kW
Defrost Power:		0.5 kW
Current consumption:		1.32 Amps
Plug type:		CE-SCHUKO
Energy consumption (min,default):		0 - 0 kW/h

### Key Information:

Gross capacity:	1430 lt
Net Volume:	1135 lt
Door hinges:	1 Left+1 Right
External dimensions, Width:	1441 mm
External dimensions, Depth:	835 mm
External dimensions, Height:	2050 mm
Number and type of doors:	2 Full
Internal Dimensions, Width:	1291 mm
Internal Dimensions, Depth:	707 mm
Internal Dimensions, Height:	1515 mm
Net weight:	190 kg
Shipping volume:	2.82 m <sup>3</sup>
Height adjustment:	0/0 mm
Number and type of grids (included):	6 - GN 2/1

### Refrigeration Data

Control type:	Digital
Compressor power:	
GWP Index:	3922
Refrigeration power:	0 W
Refrigeration power at evaporation temperature:	-30 °C
Refrigerant weight:	0 g
Min/Max internal humidity:	
Operating temperature min.:	-22 °C
Operating temperature max.:	-15 °C
Refrigeration type:	R404A;R452A
Operating mode:	Ventilated
Suggested refrigeration power:	965 W
Condition at evaporation temperature:	-30 °C
Condition at condensation temperature:	55 °C
Condition at ambient temperature:	32 °C
Connection pipes (remote) - outlet:	9.5 mm
Connection pipes (remote) - inlet:	6 mm

### Product Information (EU Regulation 2015/1094)

Crio Smart  
2 Door Digital Freezer, 1430lt (-22/-15) - Remote

The company reserves the right to make modifications to the products without prior notice. All information correct at time of printing.



Energy Class:

Yearly and daily energy consumption:

Climate class:

Energy Efficiency Index (EEI):



Crio Smart  
2 Door Digital Freezer, 1430lt (-22/-15) - Remote

The company reserves the right to make modifications to the products without prior notice. All information correct at time of printing.

2022.11.02